

Separate catalog available

YD2-1025S/D, YD2-2535S/D

Productivity enhancement, downtime reduction, and environment-conscious models support easy introduction in low-clearance installations

Clamping force 100 - 350 tf

Vibration control

Optimized design + Power-saving

Low posture (Double speed mechanism)

All-axis servo-driven



For CE supported languages, please contact our sales department.

All-Axis Servo Driven Take-out Robot Enhancing Customer Profitability and Environmental Measures

Combining design optimization, CFRPV3, and vibration control contribute to shorter cycle time and stable take-out. We have refined our unique ECO Vacuum™ technology to reduce compressed air consumption even further. As a result, robot air consumption can be economized and can reduce capital expenditures. The YD2-1025/2535 is sized for molding machines with clamping forces from 100 to 350 tf.

Equipped with E-touch compact 3 as standard



- Smart ECO Vacuum
- Take-out Diagnosis Function
- Torque Monitoring during Manual Operation

The E-touch compact 3 takes the easy operability of the previous YC series controller. And several assist features to become even easier to use.

Standard Specifications

Power supply		Drive method		Controller model		Working air pressure		Flip angle		
1 phase AC200/220 V (50/60 Hz)		Digital servo motor 3/5-axis		E-touch compact 3		0.49 MPa		90°		
Model	Power consumption	Traverse stroke [mm]	Kick stroke [mm]		Vertical stroke [mm]		Air consumption [NL/cycle]	Payload [kg]	Noise [dBA]	Target IMM clamp capacity [tf]
			Main arm	Sub arm	Main arm	Sub arm				
YD2-1025S	S type 1.9 kVA AC200 V 9.3 A	(1100)	578	—	(700)	—	5.6 Smart ECO Vacuum OFF	5 (8)	75.9	100-250
YD2-1025D		1500 (1700) (1900)	518	518	850 (950)	(700) 850 (950)	1.5 Smart Eco Vacuum ON			
YD2-2535S	D type 2.5 kVA AC200 V 12.3 A	(2200) (2500)	728	—	950 (1100)	—	5.9 Smart ECO Vacuum OFF	75.6	250-350	
YD2-2535D			668	668	950 (1100)	950 (1100)	1.7 Smart ECO Vacuum ON			

S type : Robot is equipped with main arm only. D type : Robot is equipped with main arm and sub arm.
() : Modified stroke () : Increased maximum payload
Payload includes the end-of-arm tool.

Rear (Non-operator) Side Discharge Direction [mm]

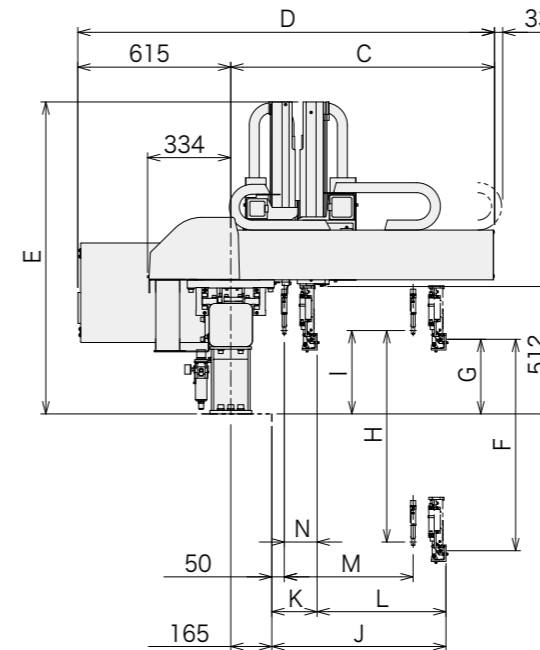

Operator Side Discharge Direction [mm]

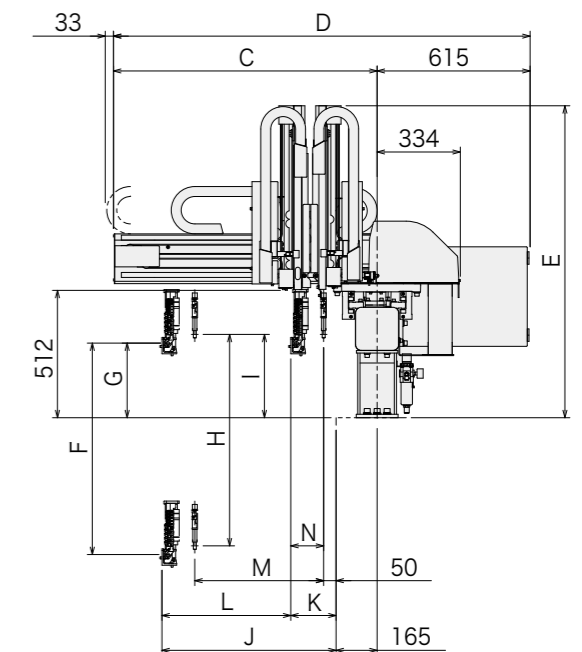
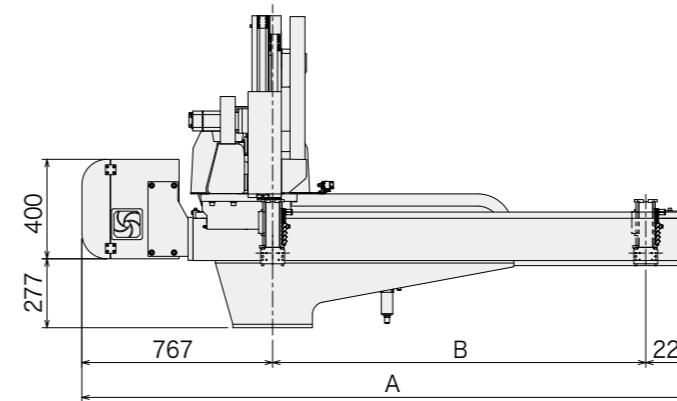

[mm]

Model	A	B	C	D	E	F	G	H	I	J	K	L	M	N
YD2-1025S								—	—		122	578	—	—
YD2-1025D	(2087) 2487 (2687) (2887) (3187) (3487)	(1100) 1500 (1700) (1900) (2200) (2500)	1060	1675	(1182) 1254 (1310)	(700) 850 (950)	300	(700) 850 (950)	335	700	182	518	518	132
YD2-2535S								—	—		122	728	—	—
YD2-2535D			1210	1825	1310 (1382)	950 (1100)		950 (1100)	335	850	182	668	668	132

() : Modified stroke

YD2-1025S/D, YD2-2535S/D

All-Axis Servo Driven Type Take-Out Robot